

REINHOLD ENVIRONMENTAL Ltd.



**2018 NO_x-Combustion Round Table
& Expo Presentation**

February 19-20, 2018, in St. Louis, MO / Hosted by Dynegy

All presentations posted on this website are copyrighted by Reinhold Environmental, Ltd (RE). Any unauthorized downloading, attempts to modify or to incorporate into other presentations, link to other websites, or obtain copies for any other uses than the training of attendees to RE's Conferences is expressly prohibited, unless approved in writing by RE or the original presenter. RE does not assume any liability for the accuracy or contents of any materials contained in this library which were presented and/or created by persons who were not employees of RE.

Ammonia Injection and Mixing Systems 101

Kanthan Rajendran, P.E.
Airflow Sciences Corporation

2018 NOx-Combustion-CCR Round Table
February 19, 2018
St Louis, MO

Agenda

- Intro
- Coal Fired SCR
- Gas Turbine SCR

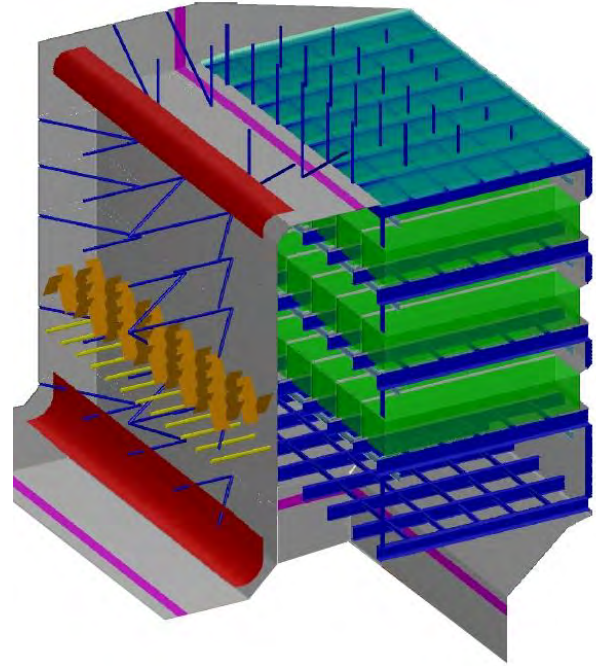
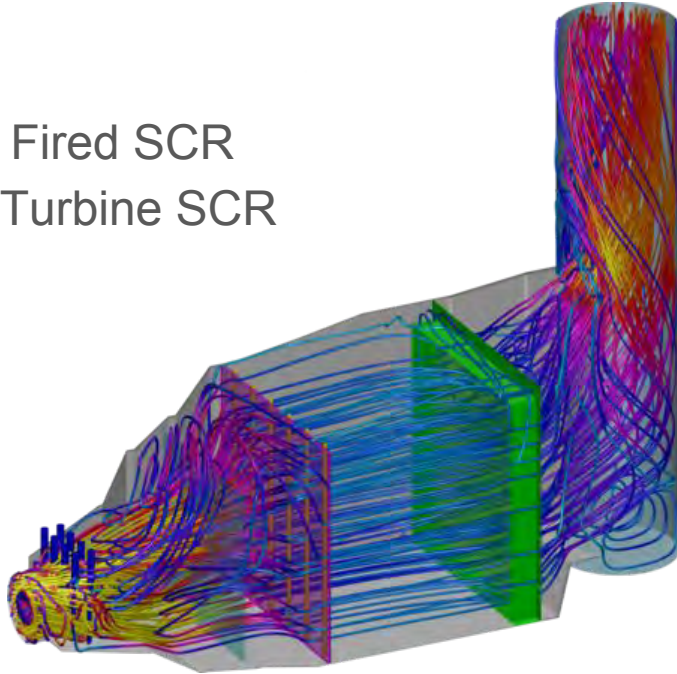

NO_x Control

- Nitrogen oxides, also known as NO_x, are important air pollutants by themselves; also react in the atmosphere to form ozone (O₃) and acid rain
- NO_x is formed in the boiler at temperatures greater than 3600°F
- 95% of NO_x in the flue gas is initially in the form of NO, rest is NO₂
- Once in the atmosphere, most NO_x is converted into NO₂ form
- Typical SCR systems can achieve NO_x removal efficiencies over 90%



Selective Catalytic Reduction

Selective catalytic reduction (SCR) is a chemical process of using a reductant like ammonia to convert NOx into diatomic nitrogen (N₂) and water (H₂O), with the aid of a catalyst.

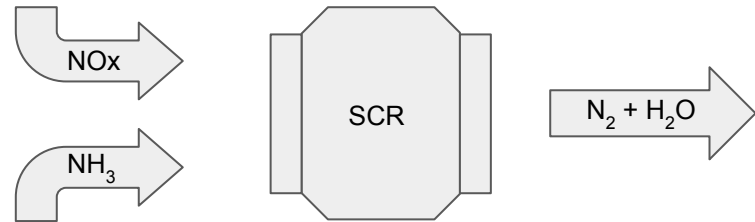
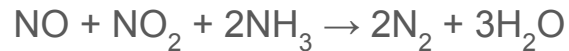
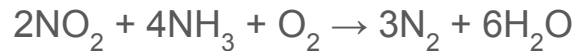

Ammonia has to react with NOx at the molecular level.

What Do You Mix for SCR?

- Ammonia
- NOx
 - Mixing may be needed if incoming NOx distribution is not uniform
- Ammonia-to-NOx ratio
 - Getting the right amount of ammonia for the amount of NOx present
- Temperature
 - SCR reactions occur optimally within a specific temperature range

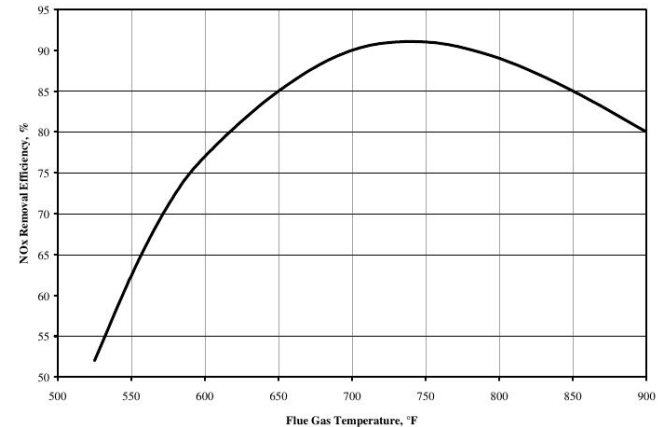

NOx Removal Efficiency vs Temperature

Why Do You Mix?

Ammonia must be dispersed and mixed thoroughly with the flue gas to maximize contact between the reactants. NO_x removal rate highly dependent on level of mixing.

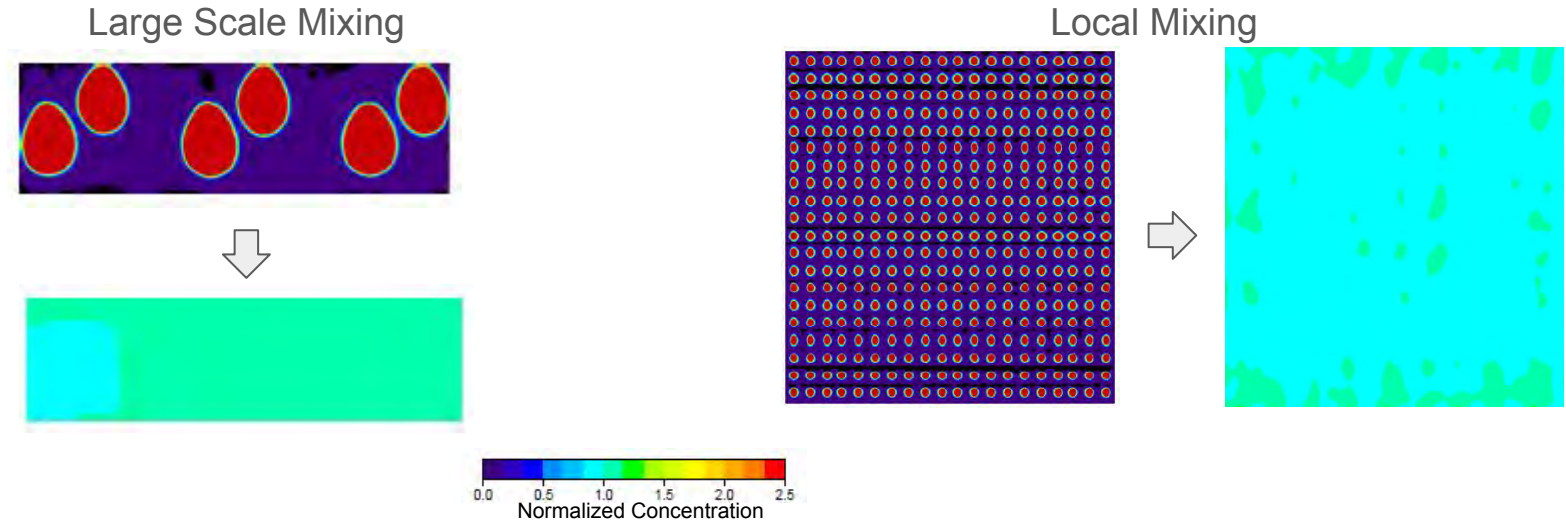

How Do You Mix?

- Control the flow streams at the injection location
 - Multi-point injection
 - Nozzle design
 - Diffusion + turbulence
- Churn up the flow after the injection
 - Induce high turbulence
 - Create shear forces
 - Generate swirl or vortices

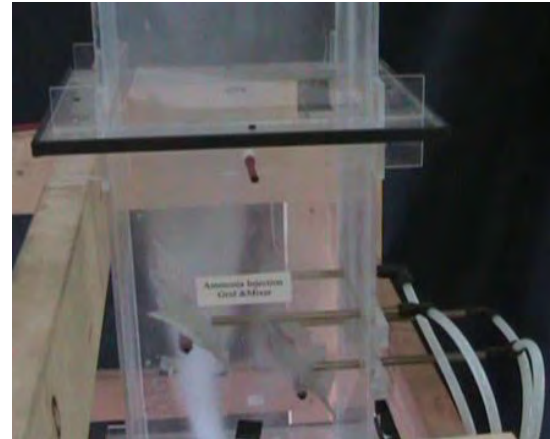
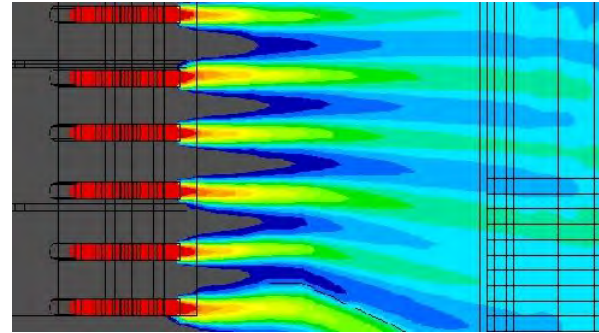

Where Do You Mix?

For Coal Fired SCR:

- NOx & temperature
 - upstream AIG
 - “Premixer”
- Ammonia
 - at or after injection location

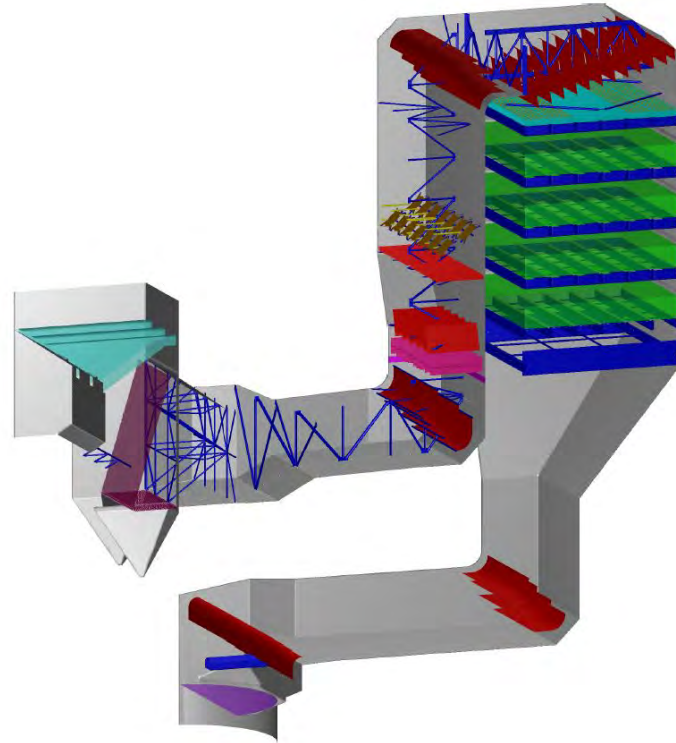

Where Do You Mix?

For Gas Turbine SCR:

- NO_x is typically uniform
- Temperature
 - upstream of CO catalyst
 - For systems with tempering air or duct burners
- Ammonia
 - at or after AIG



Coal Fired SCR Performance Goals

Typical performance goals compete with each other:

- Uniform ammonia-to-NOx ratio
- Uniform velocity at AIG and catalyst
- Vertical flow entering catalyst
- Uniform temperature at catalyst
- Capture LPA with screen/baffles
- Minimize pluggage potential
- Minimize pressure loss
- Minimize erosion potential

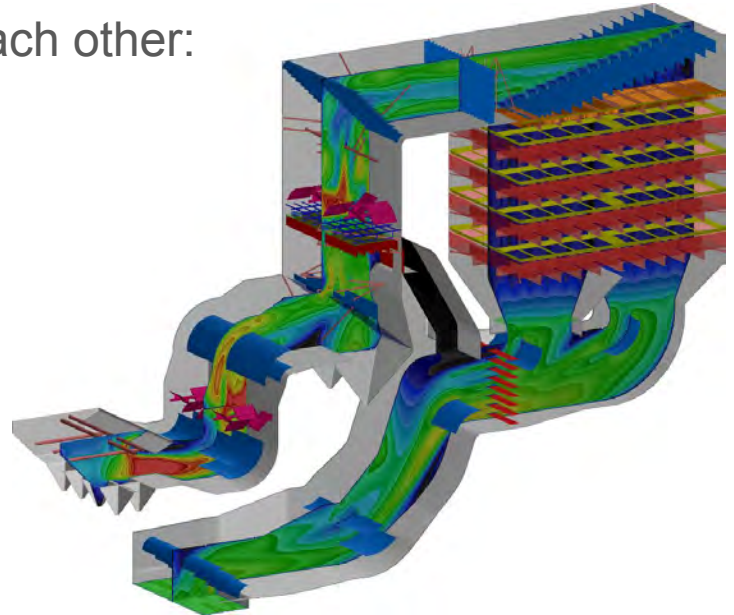

Ammonia-to-NOx Ratio

- Ammonia-to-NOx ratio at the catalyst inlet plane should be “uniform”
- Allows optimal NOx reduction with minimum ammonia slip
- Typical goal is %RMS < 5% or deviation within +/-5% of mean
- Can be highly influenced by velocity patterns

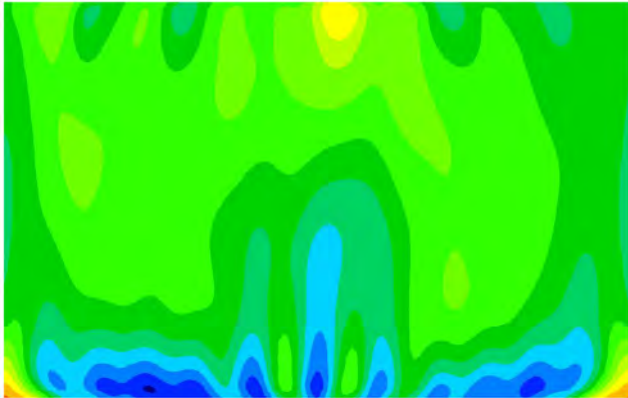

Poor
Distribution

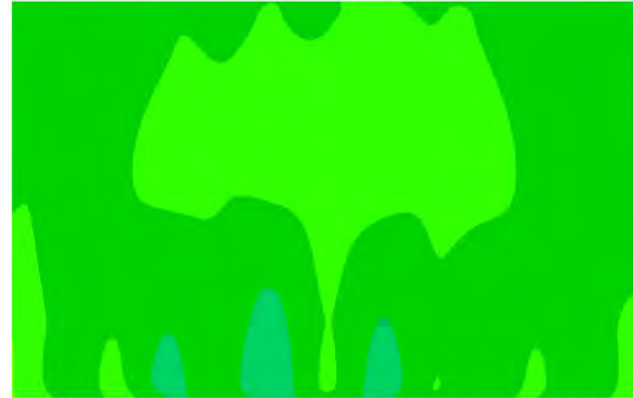

Better
Distribution

NOx Stratification

- NOx is not necessarily uniform at the boiler exit; it is a function of
 - Boiler design
 - Burner air flow balance
 - Coal pipe balance
 - Mills out-of-service
- Solutions
 - Mix the NOx prior to the NH₃ injection – “Pre-mixer”
 - Mix the NOx and the NH₃
 - Tune the NH₃ to the NOx profile
 - Consistency over load range important

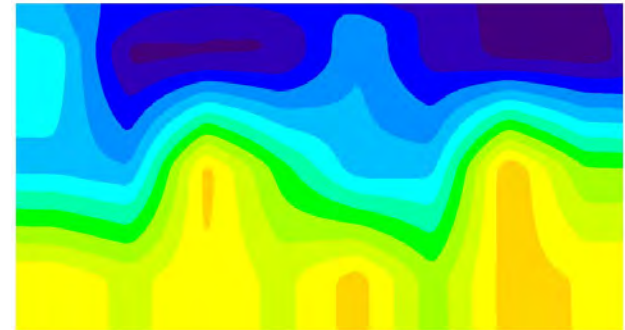

Example of NOx Profile at Economizer Outlet

Ammonia Injection

- Two basic strategies are used for ammonia injection in SCRs
 - Dense grid of injection pipes
 - Coarse grid of injection pipes with mixers

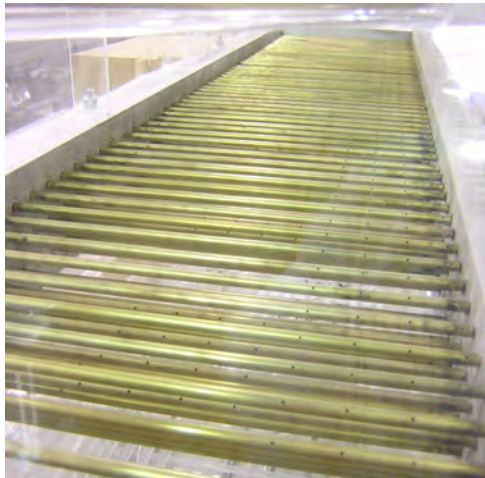

Dense Grid Ammonia Injection

- Many injection lances with multiple nozzles per lance
 - Depending on SCR size, could have 50-100 lances per reactor
 - Typically 6-10 nozzles per lance
 - Hundreds of discrete injection points
- Often no mixer or only a “local” mixer
- Lances grouped into zones for tuning
- Benefits of dense grid injection
 - More tunable for maximum NOx reduction
 - No negative influence on velocity or flyash distribution at catalyst
 - Lower pressure drop

Dense Grid AIG Issues

- Pluggage of nozzles
- Requires very good velocity profile at AIG location
- Tuning not as predictable as sometimes envisioned
 - Velocity distribution issues
 - Unequal flow per nozzle
 - Low resolution of reactor outlet sample grid
- Valve issues over time

Coarse Grid Ammonia Injection

- Fewer injection lances compared to dense grid by factor of 5-10
 - Depending on SCR size, could have 5, 10, 20 lances per reactor
 - Some systems have just 1 injection point per lance
 - Others have multiple nozzles per lance (2 to 10)
- Lances located immediately upstream of a static mixer
- Often multiple stages of static mixers
- Benefits of coarse grid injection
 - Fewer nozzles and larger openings less prone to pluggage
 - Mixing and high turbulence reduces sensitivity of gradients
 - Does not need as much tuning?
 - More consistent performance over the load range

Coarse Grid AIG Issues

- Higher pressure loss
- Duct wall and internal structure erosion
- Ash accumulation on mixers
- Tuning not as straightforward due to purposeful creation of turbulence



Vaporized Ammonia Injection vs Direct Injection

- **Vaporized Ammonia Injection**
 - utilizes vaporizer skid to get ammonia into gaseous form prior to injection
 - need to ensure ammonia properly vaporized and mixed with dilution air
 - more common but higher capital cost
- **Direct Injection**
 - inject aqueous ammonia directly in liquid form without dilution air or vaporization
 - relies on heat from flue gas for vaporization
 - requires special spray nozzles to insure proper vaporization and mixing
 - concern about liquid ammonia impingement on walls, mixer

Types of Mixers

- Shear Mixers
- Swirl-Shear Mixers
- Vortex Mixers



Shear Mixers

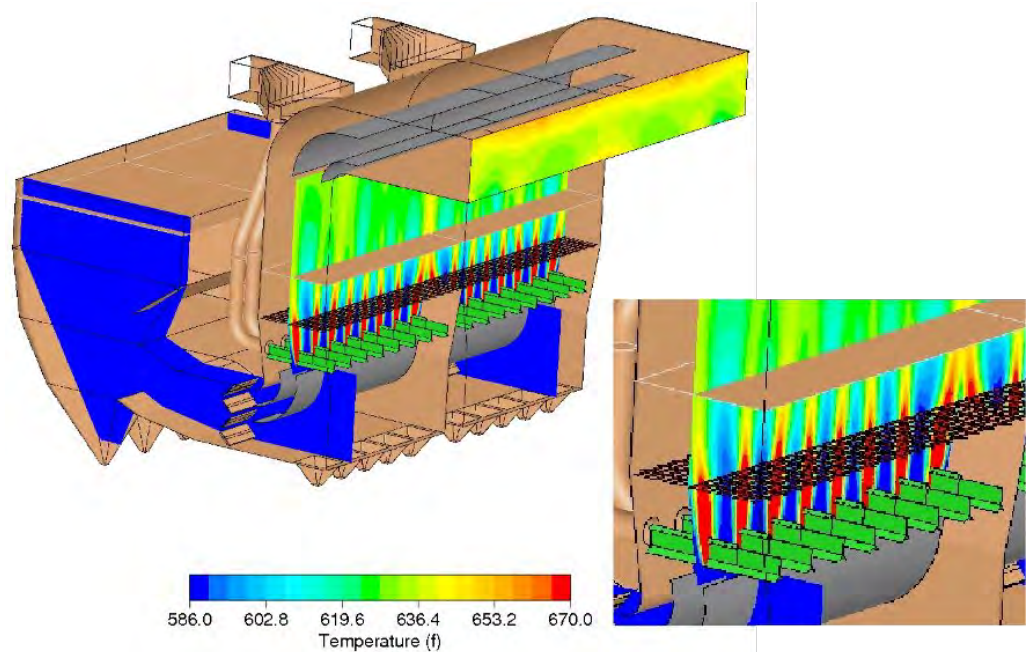

Swirl-Shear Mixers

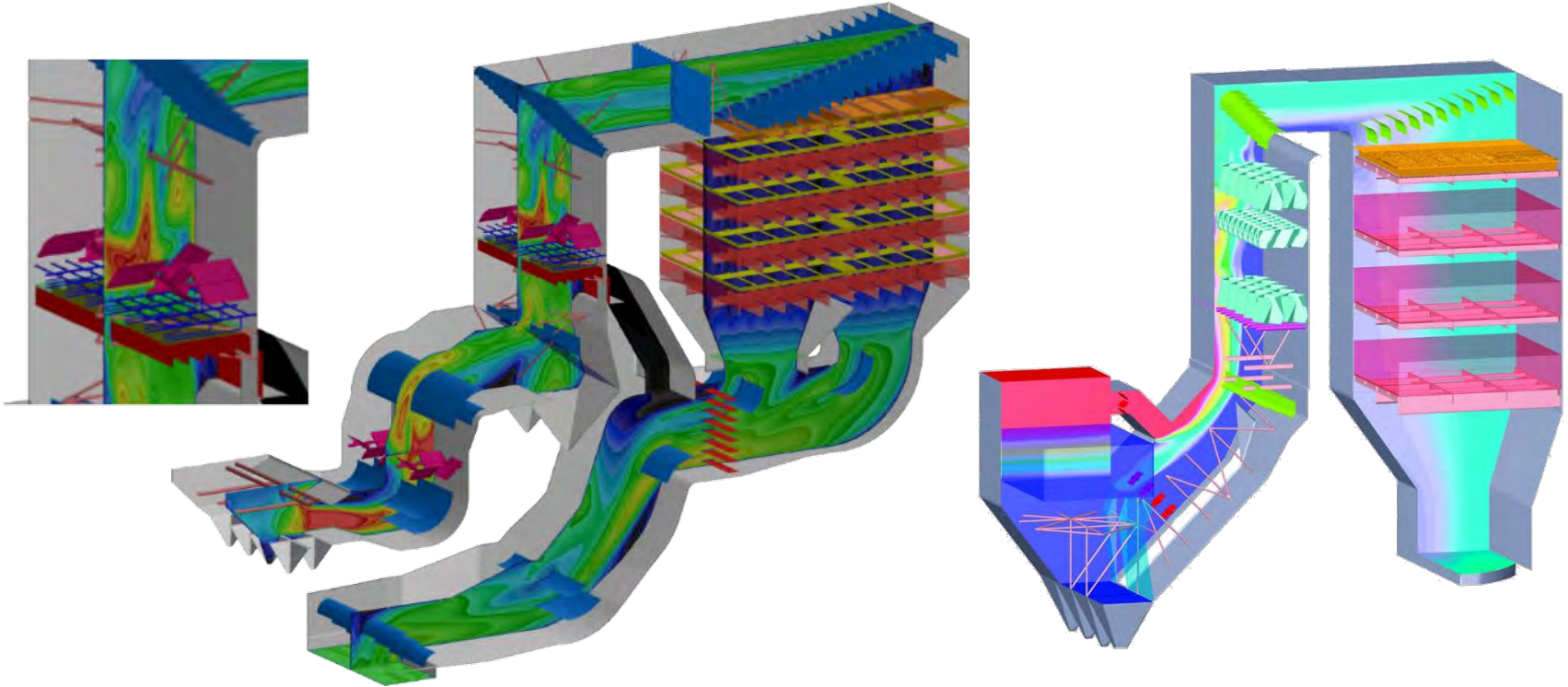

Vortex Mixers

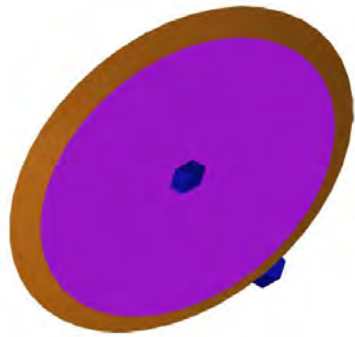

Geometry

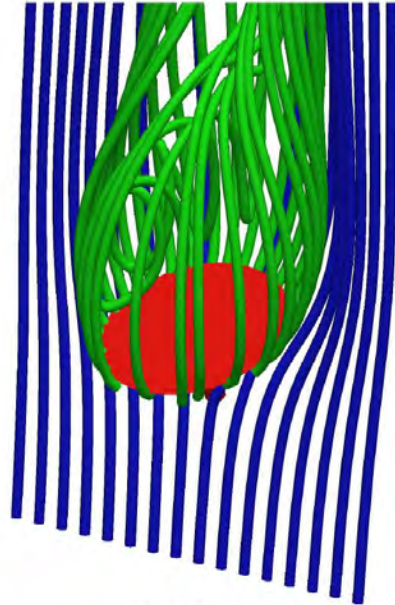

Fluid path lines



Geometry

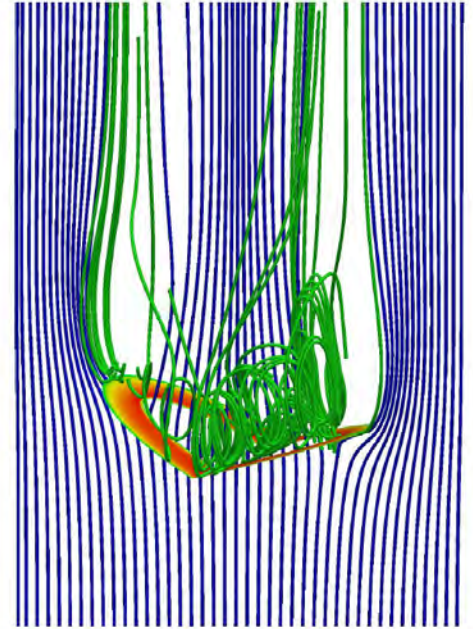

Fluid path lines

Vortex Mixers

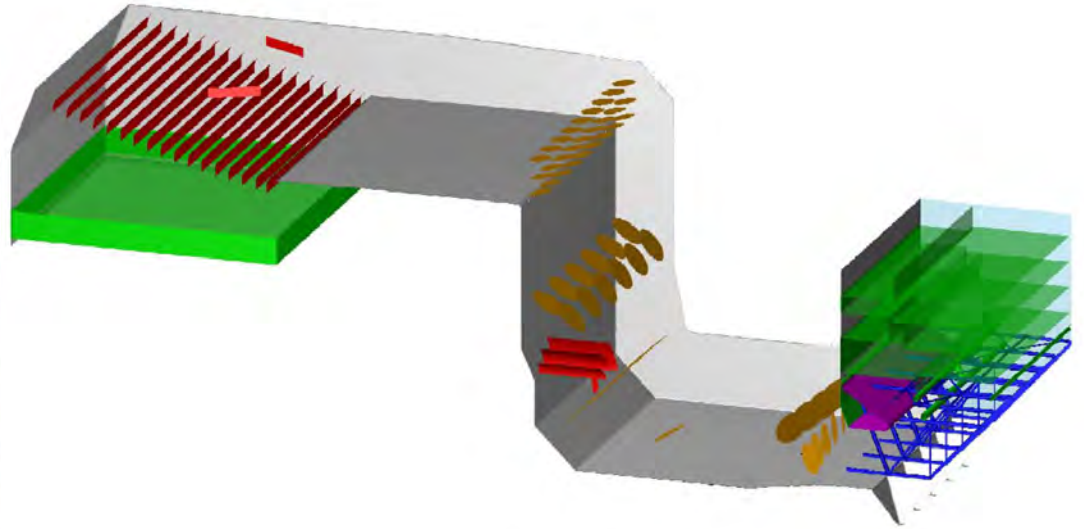

Vortex Mixers

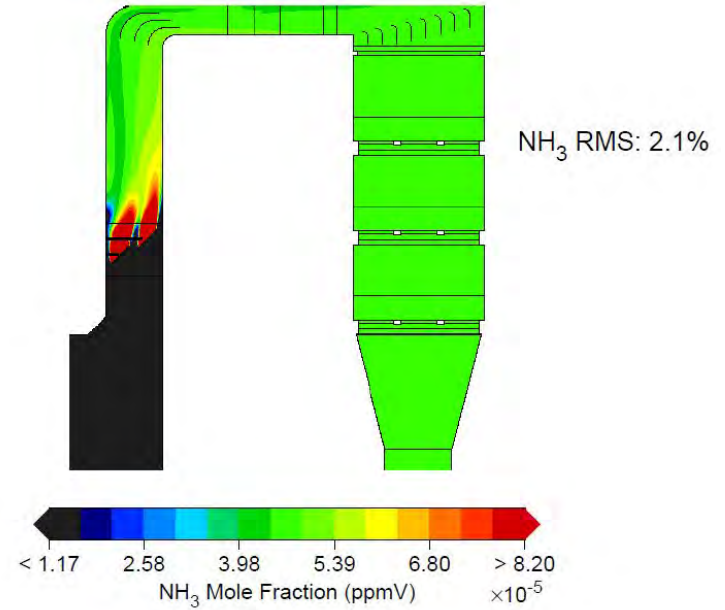
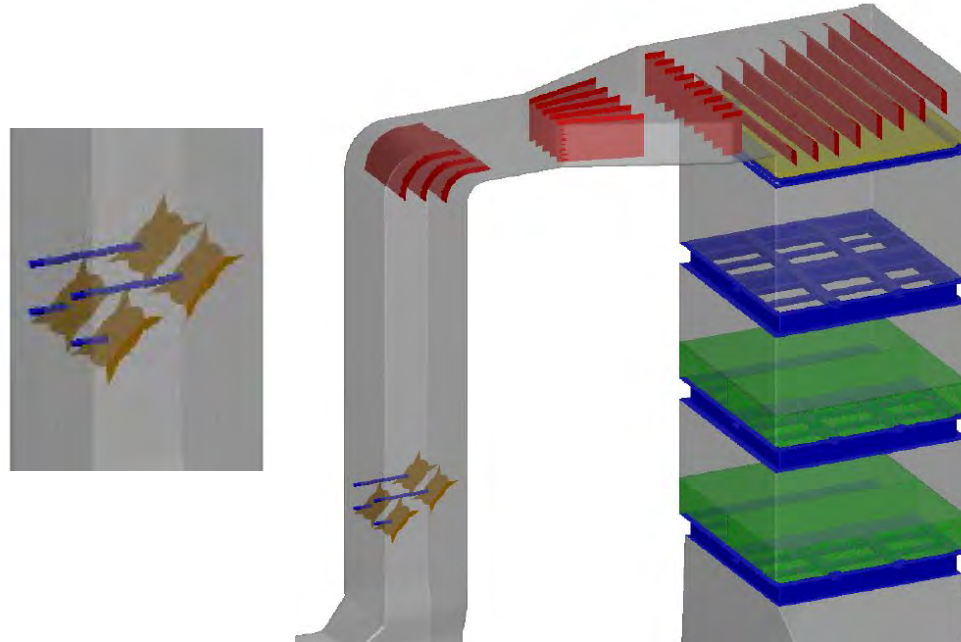

Mixer Issues

Erosion

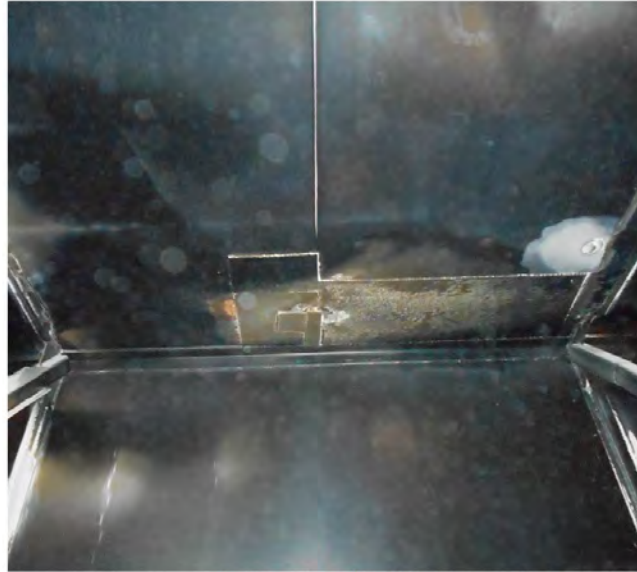
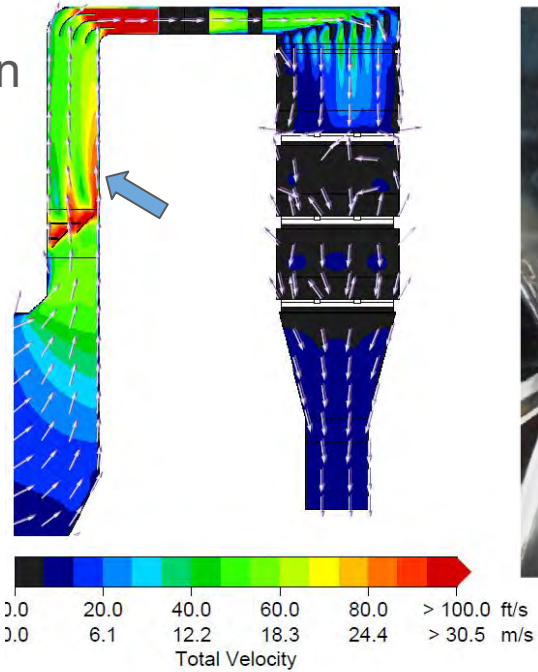

Mixer Issues

Pressure Drop

	Location	Total Pressure Loss (inH2O)	Total Pressure Loss (mmH2O)
A	Evaporator Outlet	0	0
B	Upstream AIG	-0.03	-0.8
C	Downstream AIG	-0.75	-19.1
D	Upstream SCP Duct Expansion	-0.95	-24.1
E	Downstream SCP Duct Expansion	-1.07	-27.1
F	Upstream Flow Rectifier	-1.23	-31.2
G	Upstream (Future) 1st Catalyst Layer	-1.26	-32.1
H	Upstream 2nd Catalyst Layer	-1.29	-32.7
I	Upstream 3rd Catalyst Layer	-2.30	-58.3
J	Downstream 3rd Catalyst Layer	-3.29	-83.7
K	Economizer Inlet	-3.31	-84.0
A-K	Total DP, Evaporator Outlet to Economizer Inlet	3.31	84.0
A-K	Total DP, Excluding Catalyst Layers	1.27	32.3

DP = 0.72 IWC

Typical mixer stage
DP = 0.3 to 0.8 IWC

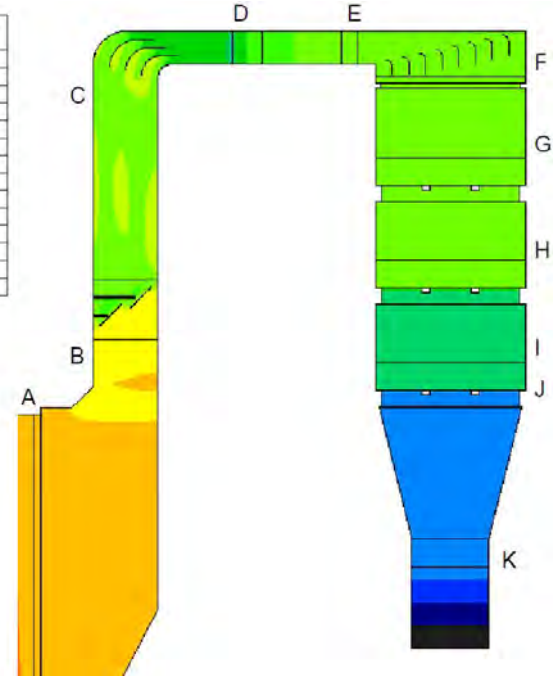

Summary – Coal Fired SCR

- NH_3 , NO_x , and temperature distributions are key players in SCR performance
- Pre-mixer often used for NO_x and temperature at boiler outlet
- Dense Grid injection generally no mixer or “local” mixer
- Coarse Grid injection will have 1 or more high turbulence mixer layers
- Ammonia injection and mixer design involves many competing criteria which must be understood and optimized

Gas Turbine SCR

- Gas turbine systems come in many sizes and flavors
 - Simple cycle
 - Combined cycle / HRSG
 - With / without CO catalyst
 - With / without tempering air



Gas Turbine SCR Performance Goals

Typical performance goals compete with each other:

- Uniform ammonia-to-NOx ratio
- Uniform velocity at AIG and catalyst
- Uniform velocity at CO catalyst
- CO catalyst influence on SCR
- Uniform temperature at catalyst
- Minimize pressure loss

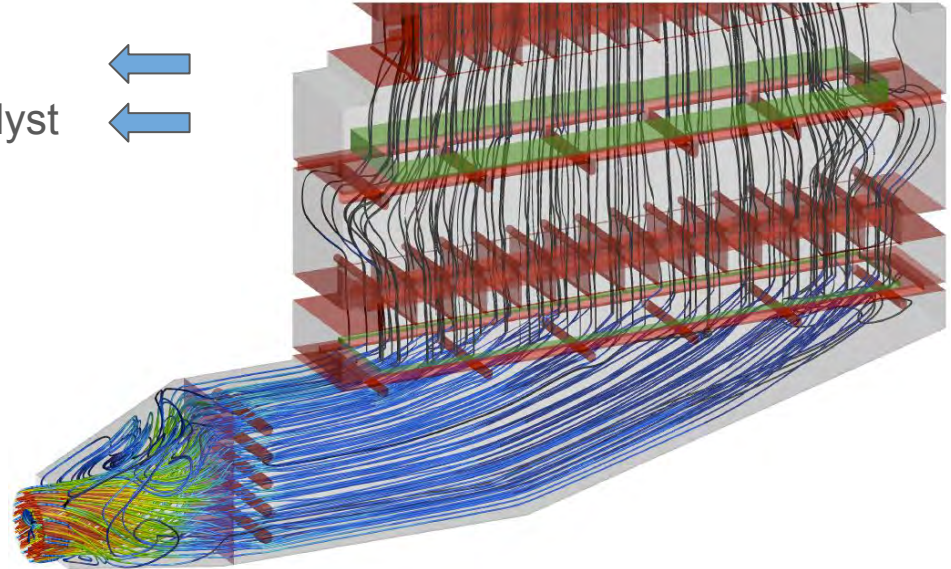

Flow Distribution in Gas Turbine SCR

- Gas Flow Through System
 - Uniform velocity profile (15% RMS or better) at
 - CO/NOx/Dual Action Catalyst
 - AIG
 - Tube banks
- Not easy given that the inlet condition resembles a tornado
- Requires intricate design of flow devices
 - Baffles
 - Straighteners
 - Perforated plates

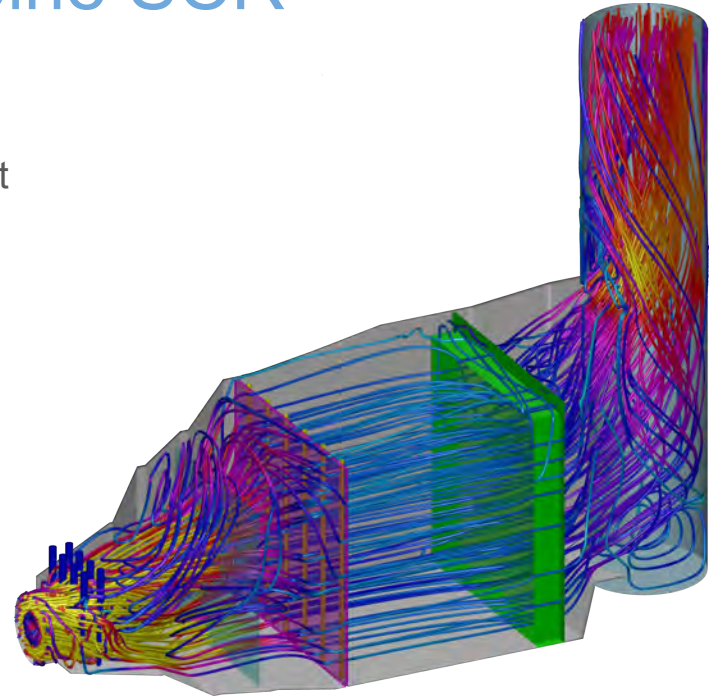

Flow Streamlines in a HRSG CFD model

Ammonia Injection in Gas Turbine SCR

- Design considerations for ammonia injection
 - The key factor in deNO_x performance and ammonia slip
 - Goal is uniform concentration (ammonia-to-NO_x ratio) at SCR catalyst
 - General target is 5% RMS or better
 - Optimization requires balance of competing goals
 - Velocity profile at AIG & SCR catalyst
 - Pressure drop
 - AIG design is not straightforward
 - Residence time for mixing is limited
 - Temperature heat up can affect distribution
 - Updated design practices have led to advances
 - Older systems likely have room for improvement

Ammonia Injection Grid

- **AIG Design:**
 - General goal is to inject equal ammonia from each nozzle to within 2% or better
 - Correct sizing of header ID, lance ID, and nozzle diameters is important
 - Need to consider heat transfer from gas side to the internal pipe flow; this can influence the balance between nozzles
 - The presence of tuning valves cannot always fix a poor AIG header/lance design

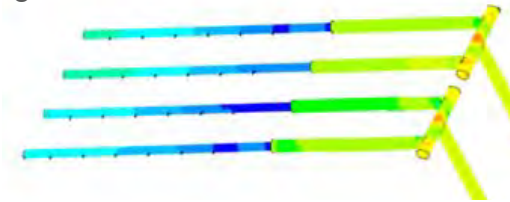
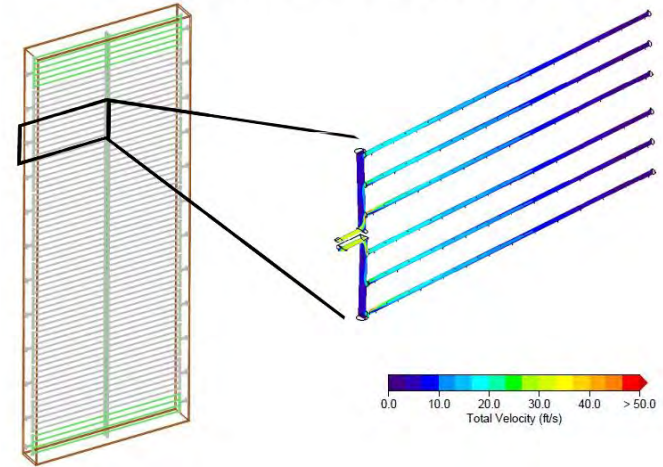

Flow Modeling of AIG header and lances

Ammonia Distribution at SCR

- Need to ensure sufficient number of lances/nozzles to cover the cross section
- Depends on residence time to catalyst and turbulence intensity
- Additional mixing may be required depending on geometry details
 - Static mixer after AIG
 - Turbulence generators integrated with AIG
- Modeling and testing to guide design

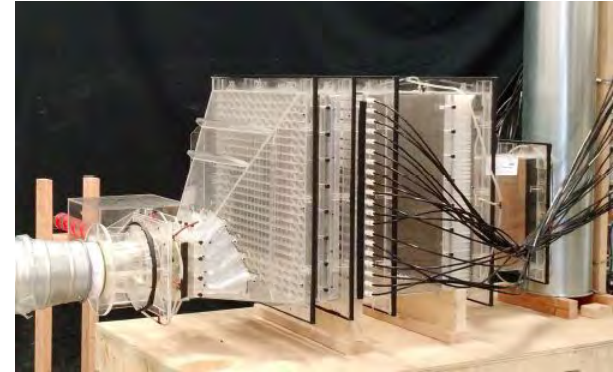

AIG Optimization Case Study

- HRSG unit struggling with poor ammonia distribution at the SCR catalyst and high ammonia slip.
- Plant AIG tuning was not successful, could not eliminate high ammonia gradients near walls
- CFD model corroborated field data showing velocity profile at the AIG having large areas of low flow or recirculation, which would allow ammonia to accumulate.

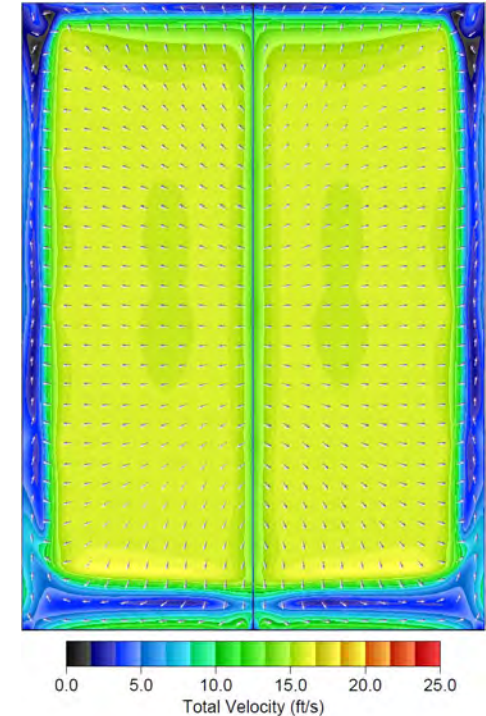
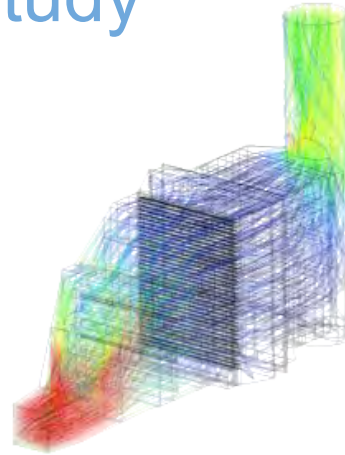

AIG Optimization Case Study

- CFD model indicates very high ammonia concentrations near the walls of the unit.
- Ammonia RMS of 59% at the SCR catalyst face.

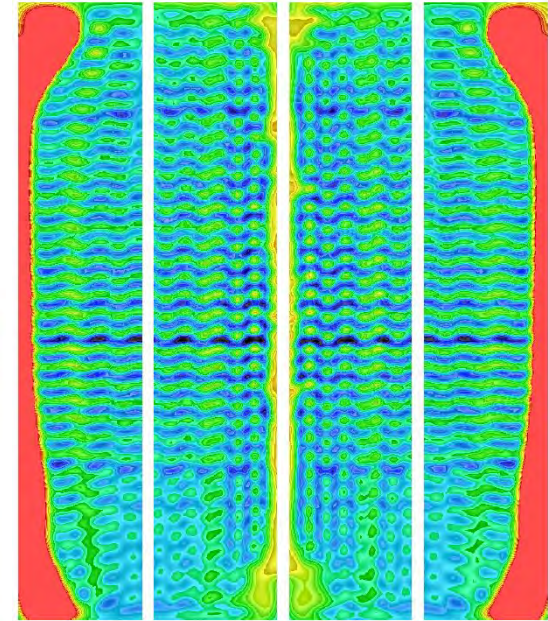
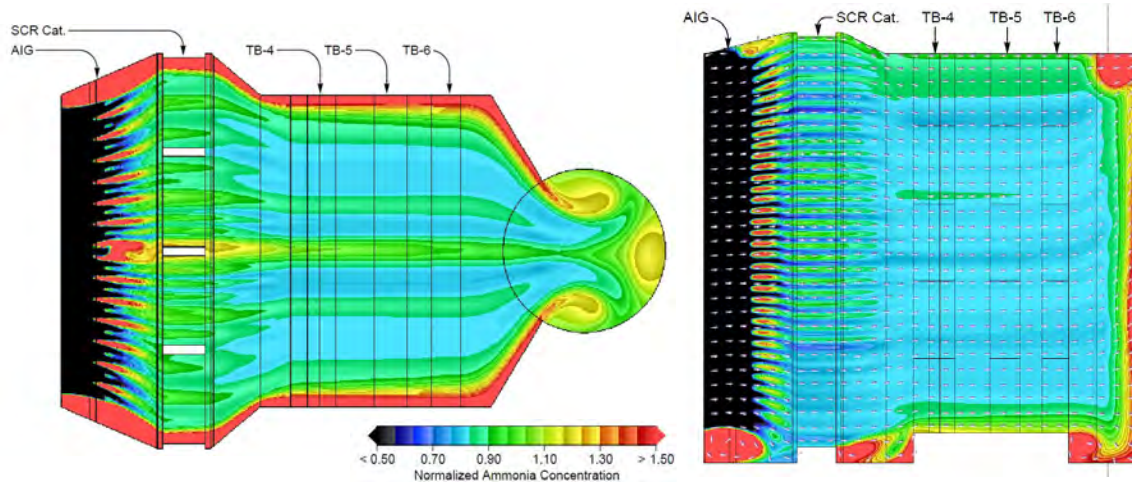

Ammonia Distribution RMS of 59%
at SCR Catalyst Face

AIG Optimization Case Study

- AIG modifications added to improve local mixing and ammonia distribution
- Ammonia RMS improved to 8% at the catalyst face

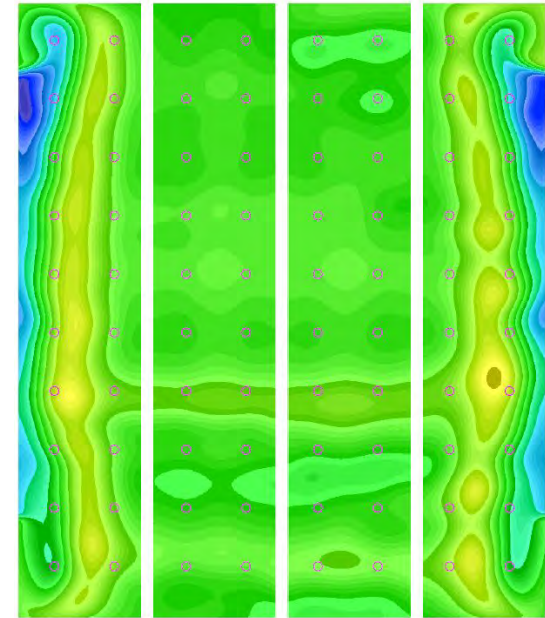
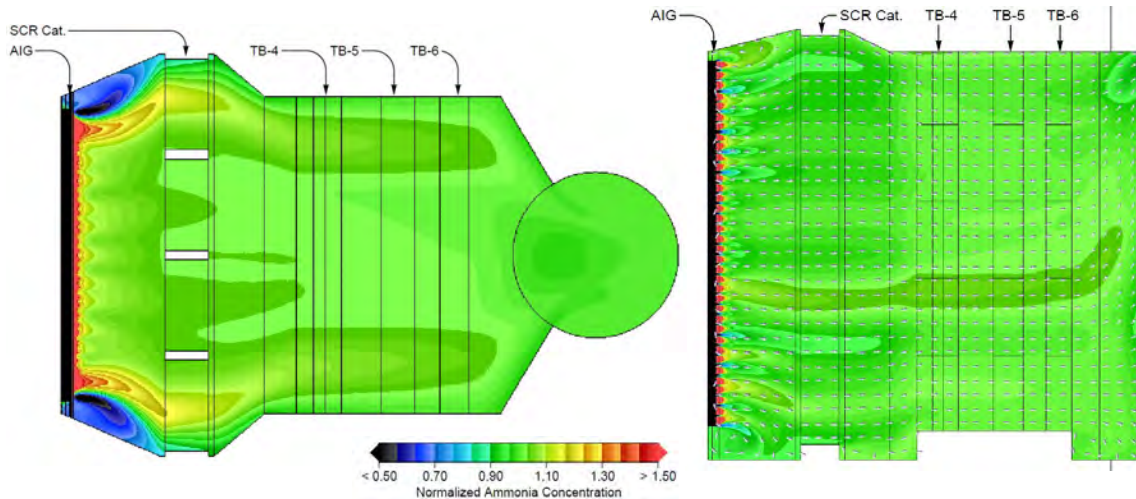

Ammonia Distribution RMS of 8%
at SCR Catalyst Face

Summary – Gas Turbine SCR

- There are many parameters that affect gas turbine and SCR performance
- AIG design involves many competing criteria which must be understood and optimized
- Residence time is usually quite limited in gas turbine SCR; local mixer may be necessary
- Need optimized design at beginning, and design improvements over time
- Cost-effective enhancements are possible to existing systems

Questions & Contact Information

Kanthan Rajendran, P.E.

Project Engineer

734-525-0300 x224

srajendran@airflowsciences.com

www.airflowsciences.com